

KAB// Seating

Marine Seating



KAB 515/525

KAB 300K



KAB 514C

- Fishing Trawlers
- Patrol Vessels
- Lifeboats
- Pilot Boats
- Ferries
- Motor Cruisers
- Hovercraft
- Naval Craft

ENTER THE COMFORT ZONE

www.kabseating.com

BACK
FRIENDLY

Suspension Seating suitable for many types of Marine Craft

The KAB Seating range of Suspension Seats has been designed primarily for Off-Highway vehicles such as Excavators and Dumptrucks.

Due to the demanding environments in which these types of vehicles operate, the seats are manufactured to be extremely robust, durable and most importantly ergonomically comfortable for the occupant... requirements equally important for Marine craft.

KAB Seating have successfully supplied seats to the Marine sector for over 30 years. The matrix below details the most popular seats supplied.



XH2/U5

559 ACS

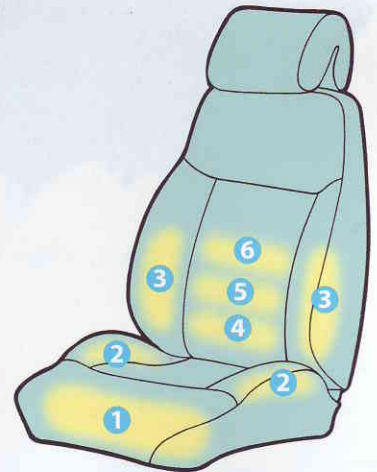

KAB Air Comfort System (ACS)

Simply press a button and the electrical pump will feed air to support the area of your preference.

Specifications

Model	Part Number	Trim	Suspension	Seat Belt	Height Riser	Headrest	Armrests	Hsc Code IMO-185 200 Approved
300K	152227	Black PVC	Mechanical	●		●	●	●
301K	151028	Storm Fabric	Mechanical	●	●	●	●	●
515	177886	Amber Fabric	Mechanical	●	●	●	●	●
525	177887	Amber Fabric	Mechanical	●	●	●	●	●
514C	169556	Krakatoa Fabric	Mechanical	● 4-POINT	●	●	●	●
559 ACS	181563	Black Leather	AIR (12v)	●	●	●	●	●
559 ACS	181564	Black Leather	AIR (24v)	●	●	●	●	●
XH2/U5	163543	Black PVC	Mechanical	●	●		●	

● Standard ● Optional

Distributor:



MARINE INTERNATIONAL

388, East Coast Road, Singapore 428990

Tel: 6447-3004 (4 Lines) Fax: 6447-4110

Website: <http://www.marine-intl.com.sg>

E-mail: marintl@magix.com.sg



KAB // Seating



**MARINE
300 K**

KAB// Seating

300 Series



**KAB 301K
MARINE**

KAB 301K



ENTER THE COMFORT ZONE

www.kabseating.com

KAB // Seating

300 Series

Mechanical suspension seating for the construction and marine sectors

Features	301K	300K
Mechanical suspension with double acting hydraulic damper	●	●
100mm vertical suspension stroke (4")	●	●
Seat height and tilt adjustment 60mm (2½")	●	
Driver weight adjustment 50-120kgs (110-265lbs)	●	●
Suspension cover	●	●
Backrest angle adjustment 12°	●	●
Fore and aft adjustment 160mm (6¼")	●	●
Seat belt widths 50mm (2") & 75mm (3")	○	○
Adjustable armrests (50/70/80/100mm)	○	○
Adjustable headrest	○	○
Cushion heaters 12v or 24v	○	○
Turntable/Mounting pedestal 0°-180°	○	○
Double damper version	● 301KS	
Range of fabrics and PVC	○	○
Flat PVC drainage cushions	○	
Vibration performance to ISO 7096	●	●
Seat belt to ISO 6683, SAE J386 and ISO 3776 (anchorage strength 15kn)	●	●
Tether belt version SAE J386 June 1985 (anchorage strength 22kn)	○	○

● Standard ○ Optional

The 300/301 series has a great reputation and has been used for many years in harsh environments. Its stable torsion bar suspension system provides maximum operator protection from harmful vibrations

Distributor



MARINE INTERNATIONAL

388, East Coast Road, Singapore 428990
 Tel: 6447-3004 (4 Lines) Fax: 6447-4110
 Website: <http://www.marine-intl.com.sg>
 E-mail: marintl@magix.com.sg

France - KAB Seating

Tel: +33 (0) 1 40 92 97 40 E-mail: info@kabseating.fr

North America - KAB Seating

Tel: +1 800 354 9621 E-mail: kabseating@nationalseating.com

Sweden - KAB Seating AB

Tel: +46 (0) 8 550 343 30 E-mail: office@kabseating.se

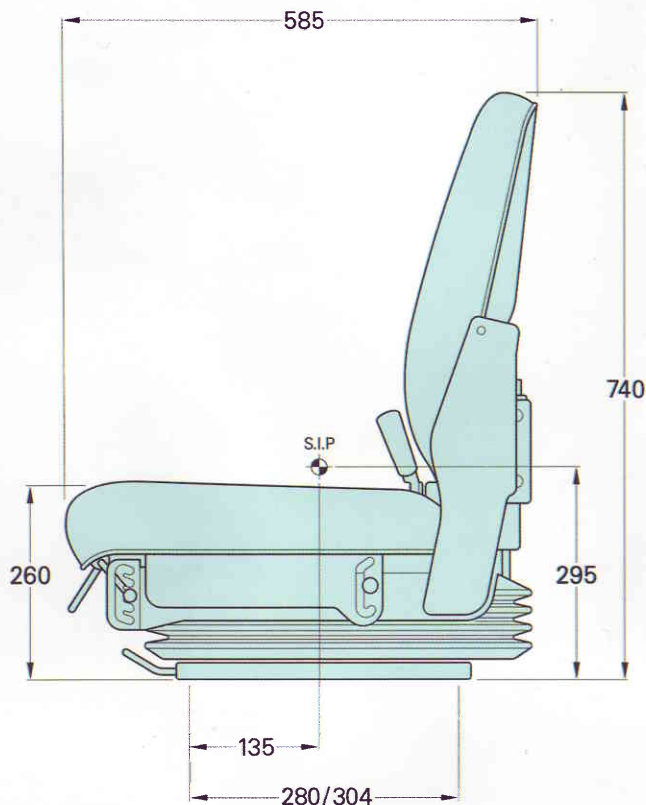
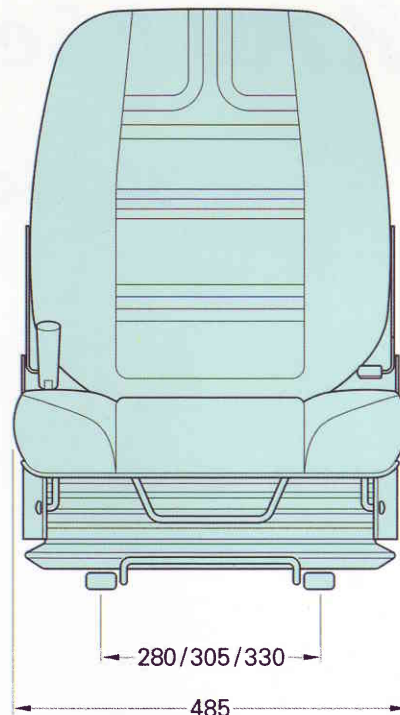

- SIP to ISO 5353.
- Dimensions at mid suspension stroke, middle height adjustment and at mid sliderail adjustment.
- Indicative dimensions
- 301K shown

These models are just part of the extensive 300 series range. Low back and static seats are also available.

For further details contact your local KAB office.

KAB // Seating

AIR 559ACS



AIR 714



301K



AIR 85/E6



211



AIR 554C



AIR 711S



XH2/P2



AIR 15/E1



AIR 714B



CONTROLLER



Construction ●

Agricultural ●

Commercial ○

Industrial/Forklift ●

Marine ●

Office ●

Mobility ●

ENTER THE COMFORT ZONE

www.kabseating.com